



High Performance Compact Pneumatic Actuators



The pneumatic rack & pinion actuator is manufactured using the latest materials and methods to provide dependable and smooth operation in demanding process control conditions.

aero² DESIGN FEATURES

- ✓ Hard Anodized aluminum housing
- ✓ "Versa-View" Continuous mechanical position indicator
- ✓ Stainless Steel drive shaft and trim.
- ✓ ISO/NAMUR design for universal mounting and accessory attachment
- ✓ Bi-Directional Stroke Adjustment
- ✓ 1/4" NPT air inlet manifold
- ✓ Actuator is designed for 120 psi supply air pressure
- ✓ Optional 304 SS and 316 SS material available - Consult SVF



MATERIALS OF CONSTRUCTION

ITEM	DESCRIPTION	MATERIALS SPECIFICATIONS
1	Indicator Cap Screw	Plastic/Stainless Steel
2	Position Indicator	Plastic (ABS)
3	Pinion Snap Ring	Stainless Steel 300 Series
4	Thrust Washer	Stainless Steel 300 Series
5	Thrust Bearing	Polyoxymethylene (Delrin®)
6	Body	Extruded Aluminum Alloy
7	Piston Guide	Polyoxymethylene (Delrin®)
8	O-Ring (Pinion Top)	Viton®
9	Bearing (Pinion Top)	Polyoxymethylene (Delrin®)
10	Inside Washer	Polyoxymethylene (Delrin®)
11	Stroke Adjustment Stop	Alloy Steel
12	Pinion (Drive Shaft)	SS 300 Series/Nickel Plated Alloy
13	Bearing (Pinion Bottom)	Polyoxymethylene (Delrin®)
14	O-Ring (Pinion Bottom)	Viton®
15	Spring (Cartridge)	Spring Steel (Corrosion Resistant)
16	Bearing (Piston)	Polyoxymethylene (Delrin®)
17	O-Ring (Piston)	Viton®
18	Piston	Aluminum
19	Plug	NBR
20	O-Ring (Adjust Screw)	Viton®
21	Stop Nut (Adjust Screw)	Stainless Steel 300 Series
22	Adjust Screw	Stainless Steel 300 Series
23	Stop Screw	Stainless Steel 300 Series
24	Nut (Stop Screw)	Stainless Steel 300 Series
25	O-Ring (End Cap)	Viton®
26	End Cap	Aluminum
27	End Cap Screw	Stainless Steel 300 Series

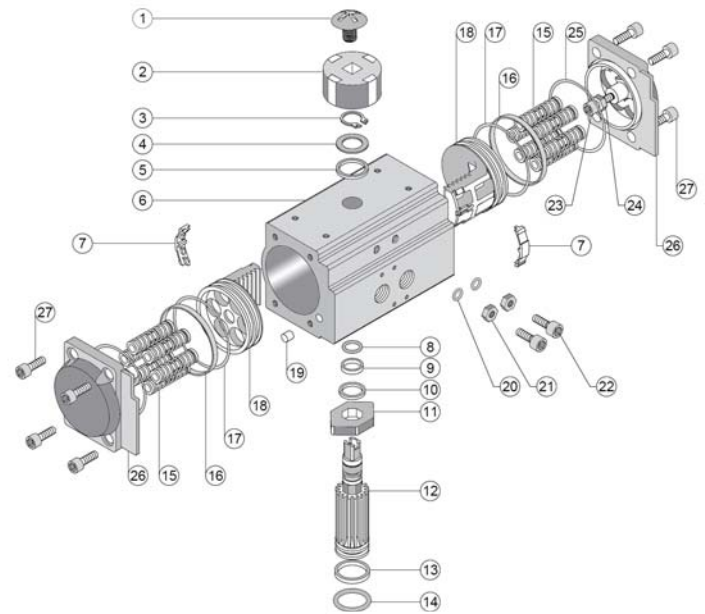

BI-DIRECTIONAL STROKE ADJUSTMENT

aero² actuators feature bi-directional pinion travel stops. These stops allow for true +/-5° for valve travel adjustment to ensure precise positioning in all flow control services. The aero² travel stops are designed to absorb the maximum rated torque of the actuator and the maximum impact loads associated with the recommended stroke speed.

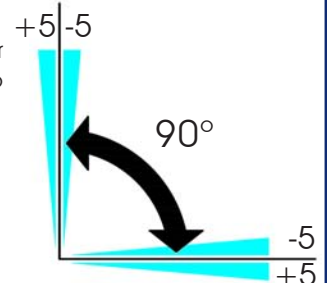

What do you need today?™

HIGH PURITY
CleanFLOW
www.CleanFLOW.net

PRO-SPEC
PROCESS SPECIFIC
www.PRO-SPEC.NET

QUALITY FLOWS
THROUGH US

High Performance Compact Pneumatic Actuators



aero² DIMENSIONAL TABLE (INCHES)

Model	A	B	C	D	E	F	G	H	J	K	L sq N (Depth)	
20	1.18	1.63	3.62	5.79	3.15	1.18	F03/1.42	F05/1.97	#10-32UNF	1/4"-20UNC	0.43	0.55
35	1.42	1.85	4.23	6.61	3.15	1.18	F05/1.97	F07/2.76	1/4"-20UNC	5/16"-18UNC	0.55	0.71
50	1.65	2.09	4.70	7.24	3.15	1.18	F05/1.97	F07/2.76	1/4"-20UNC	5/16"-18UNC	0.55	0.71
75	1.81	2.24	5.07	10.31	3.15	1.18	F05/1.97	F07/2.76	1/4"-20UNC	5/16"-18UNC	0.67	0.83
110	1.97	2.30	5.39	10.31	3.15	1.18	F05/1.97	F07/2.76	1/4"-20UNC	5/16"-18UNC	0.67	0.83
160	2.26	2.52	6.02	10.55	3.15	1.18	F07/2.75	F10/4.02	5/16"-18UNC	3/8"-16UNC	0.87	1.02
255	2.66	2.93	6.89	11.65	3.15	1.18	F07/2.75	F10/4.02	5/16"-18UNC	3/8"-16UNC	0.87	1.02
400	2.95	3.03	7.54	15.35	3.15	1.18	F10/4.02	F12/4.92	3/8"-16UNC	1/2"-13UNC	1.06	1.22
500	3.43	3.43	8.54	18.03	3.15	1.18	F10/4.02	F12/4.92	3/8"-16UNC	1/2"-13UNC	1.06	1.22
550	4.06	4.06	9.84	20.79	5.12	1.18	-	F14/5.51	-	5/8"-11UNC	1.42	1.57
600	4.45	4.45	11.22	22.20	5.12	1.18	-	F14/5.51	-	5/8"-11UNC	1.42	1.57
650	5.12	5.12	12.55	23.70	5.12	1.18	-	F16/6.49	-	3/4"-10UNC	1.81	1.97
700	5.79	5.79	14.01	27.80	5.12	1.18	-	F16/6.49	-	3/4"-10UNC	1.81	1.97

aero² - WEIGHTS

Model	A2D		A2S	
	lbs	kg	lbs	kg
20	3	7	3	7
35	4	2	4	2
50	6	2	6	2
75	7	3	7	3
110	10	4	12	5
160	13	5	14	6
255	19	9	22	10
400	25	14	29	16
500	36	22	44	26
550	70	31	78	35
600	76	35	85	39
650	106	48	135	61
700	163	74	216	98

HOW TO ORDER *aero²* ACTUATORS

Series	Model	Springs	Seals	Options
A2D = Double Acting	20	Blank =	V =	180 =
A2S = Spring Return	35	Double Acting	Viton®	180° operation (Double Acting Only)
	50	5		
	75	6		
A2DNI =	110	7		
Double Acting with	160	8		
Nickel Infused	255	9		
Aluminum Housing	400	10*		
	500	11		
A2SNI =	550	12		
Spring Return with	600			
Nickel Infused	650	(*10 Springs are standard)		
Aluminum Housing	700			

Order Example for Model 20 Double Acting, 180° Operation: = A2D-20-V-180

A2D — 20 — V — 180

Order Example for Model 20 Spring Return, with 10 Springs: = A2S-20-10-V

A2S — 20 — 10 — V

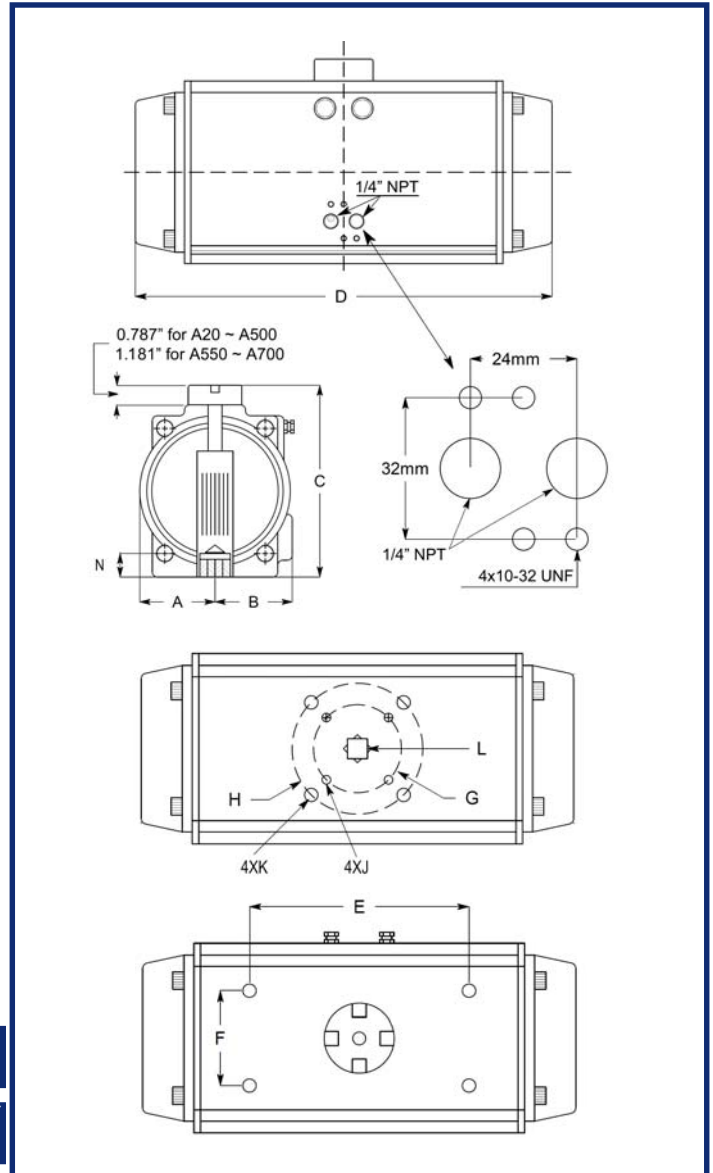



High Performance Compact Pneumatic Actuators



aero² SPRING RETURN OUTPUT TORQUES

OUTPUT AIR TO SPRING

SUPPLY PRESSURE		40		50		60		70		80		90		100		SPRING OUTPUT	
MODEL	SPRING QTY	0° START	90° END	0° START	90° END	0° START	90° END	0° START	90° END	0° START	90° END	0° START	90° END	0° START	90° END	90° START	0° END
A2S-020	5	55	37	77	58											55	38
	6	48	24	70	46	924	78									66	45
	7	39	13	61	34	90	67	120	89							77	52
	8			53	20	84	55	113	78	140	114					87	60
	9			44	8	76	44	105	67	133	104	160	132			98	67
	10					68	33	98	57	126	94	153	122			109	75
	11					60	21	91	46	119	84	146	113	172	140	120	82
	12							83	36	112	74	139	95	166	130	131	90
A2S-035	5	111	75	153	116	204	137									92	61
	6	98	55	138	95	191	152	242	205							111	72
	7	84	35	127	73	179	133	229	187							129	85
	8			111	52	167	114	218	169	267	220	315	269			148	97
	9					154	95	206	151	255	203	304	253			166	109
	10					13	75	195	133	244	186	293	236	341	286	185	121
	11							184	115	234	169	283	220	330	270	203	133
	12							171	97	222	152	271	204	320	254	222	145
A2S-050	5	141	103	197	158	270	235									128	93
	6	121	74	176	128	251	208	321	280							154	112
	7	101	47	155	99	232	182	303	256							179	131
	8			133	69	211	155	284	231	352	301	418	369			205	149
	9					192	129	266	206	335	278	402	347			231	168
	10					174	102	246	181	318	254	386	324	451	391	256	187
	11							231	157	301	231	369	301	435	369	282	205
	12							213	132	284	207	353	278	419	346	308	224
A2S-075	5	227	157	317	244	428	364									204	140
	6	196	112	285	196	400	321	508	434							244	168
	7	166	67	252	151	371	279	481	395							285	196
	8			221	103	342	237	454	355	560	466	663	572			326	224
	9					313	195	426	316	534	429	638	536			367	252
	10					284	152	400	276	508	391	613	500	715	605	407	280
	11							373	237	483	353	588	464	691	570	448	308
	12							345	198	456	316	563	428	667	536	489	336
A2S-110	5	322	214	450	338	612	511									304	207
	6	277	148	403	269	569	449	725	612							365	248
	7	231	80	355	197	526	385	685	553							426	289
	8			319	128	484	323	646	495	799	655	947	808			487	331
	9					441	260	606	436	761	599	911	755			548	372
	10					399	197	566	377	723	543	874	700	1,022	853	608	413
	11							525	318	685	487	837	647	986	801	669	454
	12						486	260	647	432	800	593	950	749	730	496	
A2S-160	5	497	325	687	508	921	760									436	280
	6	435	229	622	407	862	670	1,088	908							523	336
	7	374	133	559	308	805	580	1,035	824							610	392
	8			494	208	747	490	980	740	1,203	974	1,419	1,198			697	448
	9					689	400	927	656	1,152	894	1,370	1,122			784	504
	10					631	306	872	569	1,100	811	1,320	1,041	1,535	1,264	871	560
	11							818	487	1,048	733	1,270	966	1,486	1,191	958	616
	12						764	406	997	656	1,221	892	1,439	1,119	1,045	672	
A2S-255	5	712	453	1,000	729	1,358	1,115									698	462
	6	610	305	893	574	1,263	976	1,608	1,340							832	555
	7	509	148	787	410	1,167	828	1,519	1,202							971	647
	8			681	255	1,071	689	1,429	1,072	1,770	1,429	2,100	1,772			1,110	740
	9					976	541	1,340	934	1,685	1,298	2,018	1,645			1,249	832
	10					880	402	1,251	804	1,600	1,174	1,936	1,526	2,264	1,865	1,387	925
	11							1,161	666	1,514	1,043	1,854	1,399	2,184	1,742	1,530	1,017
	12							1,072	536	1,429	919	1,772	1,280	2,105	1,626	1,665	1,110

Specifications subject to change. Please visit www.SVF.net for the latest updates on this Data Sheet. All Data Sheets posted on our website supersede all prior publications • [Document #DDS-aero2-06_2010 • aero2 Data Sheet • 10/27/2010]

High Performance Compact Pneumatic Actuators



aero² SPRING RETURN OUTPUT TORQUES

OUTPUT AIR TO SPRING

Page 2 of 2

SUPPLY PRESSURE		40		50		60		70		80		90		100		SPRING OUTPUT	
MODEL	SPRING QTY	0° START	90° END	0° START	90° END	0° START	90° END	0° START	90° END	0° START	90° END	0° START	90° END	0° START	90° END	90° START	0° END
A2S-400	5	1,246	823	1,737	1,296	2,346	1,948									1,143	759
	6	1,082	573	1,566	1,035	2,192	1,713	2,778	2,331							1,370	908
	7	916	324	1,392	773	2,035	1,478	2,631	2,112							1,598	1,059
	8			1,218	512	1,878	1,244	2,485	1,892	3,063	2,498	3,624	3,080			1,826	1,211
	9					1,713	1,009	2,331	1,673	2,916	2,290	3,483	2,879			2,054	1,370
	10					1,557	765	2,185	1,446	2,777	2,073	3,348	2,670	3,906	3,247	2,283	1,522
	11							2,039	1,226	2,638	1,864	3,214	2,468	3,776	3,051	2,510	1,673
12							1,892	1,007	2,498	1,655	3,080	2,267	3,645	2,855	2,741	1,824	
A2S-500	5	1,877	1,212	2,640	1,943	3,592	2,966									1,844	1,236
	6	1,609	805	2,359	1,518	3,340	2,583	4,256	3,549							2,212	1,483
	7	1,332	398	2,069	1,093	3,079	2,200	4,012	3,192							2,581	1,730
	8			1,789	667	2,826	1,818	3,777	2,022	4,680	3,782	5,556	4,691			2,949	1,977
	9					2,566	1,435	3,533	2,477	4,448	3,442	5,332	4,363			3,321	2,225
	10					2,313	1,052	3,297	2,120	4,223	3,102	5,116	4,034	5,986	4,935	3,691	2,472
	11							3,062	1,771	3,999	2,769	4,900	3,714	5,776	4,624	4,056	2,719
12							2,818	1,413	3,767	2,429	4,676	3,386	5,559	4,305	4,422	2,966	
A2S-550	5	3,228	2,164	4,457	3,345	5,957	4,957									2,737	1,774
	6	2,839	1,563	4,051	2,717	5,592	4,392	7,041	5,921							3,287	2,127
	7	2,451	962	3,645	2,088	5,227	3,827	6,700	5,393							3,834	2,480
	8			3,239	1,460	4,861	3,261	6,359	4,865	7,789	6,366	9,180	7,808			4,380	2,833
	9					4,496	2,696	6,018	4,337	7,464	5,863	8,867	7,323			4,927	3,186
	10					4,131	2,131	5,677	3,809	7,139	5,360	8,554	6,838	9,936	8,269	5,473	3,540
	11							5,336	3,281	6,814	4,858	8,240	6,354	9,632	7,798	6,020	3,893
12							4,995	2,753	6,490	4,355	7,927	5,869	9,327	7,327	6,566	4,246	
A2S-600	5	3,801	2,774	5,327	4,254	7,227	6,262									3,363	2,430
	6	3,265	2,035	4,767	3,481	6,723	5,566	8,552	7,472							4,036	2,917
	7	2,728	1,295	4,206	2,707	6,218	4,870	8,081	6,822							4,708	3,405
	8			3,645	1,934	5,714	4,174	7,610	6,172	9,413	8,044	11,164	9,844			5,381	3,893
	9					5,209	3,479	7,139	5,523	8,965	7,426	10,731	9,247			6,053	4,380
	10					4,705	2,783	6,668	4,873	8,516	6,807	10,299	8,651	12,038	10,436	6,726	4,868
	11							6,169	4,223	8,068	6,188	9,866	8,054	11,617	9,856	7,399	5,356
12							5,726	3,574	7,619	5,569	9,434	7,457	11,197	9,276	8,071	5,843	
A2S-650	5	5,373	3,977	7,571	6,111	10,332	9,018									4,902	3,632
	6	4,578	2,895	6,739	4,979	9,584	8,001	12,239	10,761							5,885	4,355
	7	3,773	1,822	5,898	3,858	8,827	6,992	11,533	9,819							6,861	5,087
	8			5,066	2,727	8,079	5,975	10,834	8,869	13,451	11,579	15,989	14,184			7,844	5,810
	9					7,323	4,957	10,128	7,919	12,778	10,674	15,340	13,312			8,828	6,541
	10					6,575	3,948	9,429	6,976	12,113	9,777	14,699	12,446	17,220	15,031	9,803	7,264
	11							8,731	6,026	11,448	8,872	14,057	11,574	16,596	14,183	10,787	7,987
12							8,024	5,076	10,775	7,967	13,408	10,701	15,966	13,335	11,771	8,719	
A2S-700	5	8,786	6,576	12,163	9,852	16,289	14,210									6,961	4,952
	6	7,695	5,050	11,022	8,257	15,263	12,775	19,256	16,934							8,349	5,944
	7	6,612	3,514	9,891	6,652	14,245	11,332	18,306	15,585							9,744	6,928
	8			8,750	5,057	13,219	9,897	17,348	14,245	21,286	18,332	25,109	22,260			11,132	7,920
	9					12,193	8,453	16,389	12,897	20,374	17,048	24,229	21,023			12,527	8,912
	10					11,167	7,018	15,431	11,557	19,461	15,771	23,349	19,792	27,156	23,699	13,914	9,904
	11							14,473	10,209	18,548	14,487	22,469	18,554	26,300	22,496	15,310	10,896
12							13,523	8,869	17,643	13,211	21,597	17,324	25,452	21,300	16,697	11,880	

DOUBLE ACTING TORQUE (Lbf.-in.)				
ACTUATOR MODEL	Supply Pressure (psig)			
	40	60	80	100
A2D-020	97	146	195	244
A2D-035	178	267	356	446
A2D-050	245	368	490	613
A2D-075	383	574	766	957
A2D-110	551	827	1,103	1,378
A2D-160	808	1,211	1,615	2,019
A2D-255	1,225	1,833	2,450	3,063

DOUBLE ACTING TORQUE (Lbf.-in.)				
ACTUATOR MODEL	Supply Pressure (psig)			
	40	60	80	100
A2D-400	2,088	3,133	4,177	5,221
A2D-500	3,249	4,873	6,497	8,122
A2D-550	5,198	7,797	10,396	12,995
A2D-600	6,497	9,746	12,995	16,243
A2D-650	9,398	14,097	18,796	23,495
A2D-700	14,282	21,430	28,565	35,712

Specifications subject to change. Please visit www.SVF.net for the latest updates on this Data Sheet. All Data Sheets posted on our website supersede all prior publications • [Document #DDS-aero2-06_2010 • aero2 Data Sheet - 10/27/2010]